

BL Dimmer SXT 230VAC 100W for LED strip IP20 DALI

Article no.: 101647

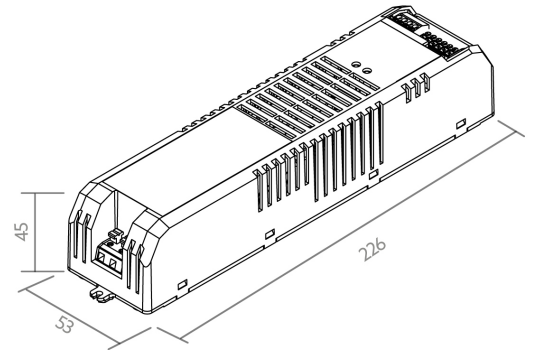

Output power range



Output current range



Input voltage range



Control signal

TENDER TEXT

1-4 channel LED dimmer for constant voltage 24VDC. Maximum total output 100W at 24VDC (max. 4A). Input voltage 230VAC/50Hz. DALI control signal. PWM frequency 600Hz. Protection class IP20. Protection class III. dimensions LxWxH = 226x53x45mm LED dimmer BILTON LEDON TechnologySXT DALI Article 101647 The SXT series is a 1- to 4 channel LED dimmer for modules in constant current operation. The total load of max. 4000 mA can be freely distributed to these 4 channels. The controller is operated with DALI and 220 - 240 V and has an output voltage of 24 VDC. The power dissipation in stand-by is 0.5 W. The dimming frequency of the PWM signal is 600 Hz. Protection degree IP20 and protection class III . Dimension (L x W x H): 226.0 mm x 53.0 mm x 45.0 mm



BL Dimmer SXT 230VAC 100W for LED strip IP20 DALI

Article no.: 101647

MECHANICAL DATA

Net width [mm]	53.0
Net height [mm]	45.0
Net length [mm]	226.0
Degree of protection (IP)	IP20
Housing	Plastic housing
Core cross section [mm ²]	0,75 - 1,5
Net weight [g]	352

ELECTRICAL DATA

Control signal	DALI
Input voltage range [V]	220 - 240
Voltage type	AC
Standby power consumption (solstandby) [W]	0.5
Output power range [W]	100
Output voltage range [V]	24
With overheating protection	yes
Overload protection	yes
Output current range [mA]	4000
Protection class	III
Number of channels	4
Dimming frequency [Hz]	600

TEMPERATURE TECHNICAL DATA

Ambient temperature during operating [°C]	- 5 ... + 45
Ambient/storage temperature [°C]	- 20 ... + 50
Operation temperature at Tc [°C]	0 ... + 50
Lifespan at 20 °C [h]	40000

PACKAGING INFORMATION

Article no.	101647
Customs tariff number	85423190
Length [mm]	226.0
Gross weight [g]	395.0
Gross height [mm]	50.0
Gross width [mm]	58.0
Gross length [mm]	252.0
State of origin	SI

NECESSARY ACCESSORIES

BL Dimmer SXT 230VAC 100W for LED strip IP20 DALI

Article no.: 101647

Article	Article no.
DALI Controller	170217
DALI USB Interface	170223

SAFETY INFORMATION: Read the safety and installation instructions carefully and completely before commissioning. The operating instructions can be found at: www.biltongroup.com

DISCLAIMER OF WARRANTY: The technical information corresponds to the status at the time of printing and have been worked out to the best of our knowledge. However, errors and printing errors are reserved. Make sure that you always use the latest version of the data sheets. The latest data sheet can be found at: www.biltongroup.com